



Standard Test Method for Surface Burning Characteristics of Building Materials¹

This standard is issued under the fixed designation E 84; the number immediately following the designation indicates the year of original adoption or, in the case of revision, the year of last revision. A number in parentheses indicates the year of last reapproval. A superscript epsilon (ϵ) indicates an editorial change since the last revision or reapproval.

This standard has been approved for use by agencies of the Department of Defense.

1. Scope

1.1 This fire-test-response standard for the comparative surface burning behavior of building materials is applicable to exposed surfaces such as walls and ceilings. The test is conducted with the specimen in the ceiling position with the surface to be evaluated exposed face down to the ignition source. The material, product, or assembly shall be capable of being mounted in the test position during the test. Thus, the specimen shall either be self-supporting by its own structural quality, held in place by added supports along the test surface, or secured from the back side.

1.2 The purpose of this test method is to determine the relative burning behavior of the material by observing the flame spread along the specimen. Flame spread and smoke developed index are reported. However, there is not necessarily a relationship between these two measurements.

1.3 The use of supporting materials on the underside of the test specimen has the ability to lower the flame spread index from those which might be obtained if the specimen could be tested without such support. These test results do not necessarily relate to indices obtained by testing materials without such support.

1.4 Testing of materials that melt, drip, or delaminate to such a degree that the continuity of the flame front is destroyed, results in low flame spread indices that do not relate directly to indices obtained by testing materials that remain in place.

1.5 The values stated in inch-pound units are to be regarded as the standard.

1.6 The text of this standard references notes and footnotes that provide explanatory information. These notes and footnotes, excluding those in tables and figures, shall not be considered as requirements of the standard.

1.7 *This standard is used to measure and describe the response of materials, products, or assemblies to heat and flame under controlled conditions, but does not by itself*

incorporate all factors required for fire-hazard or fire-risk assessment of the materials, products, or assemblies under actual fire conditions..

1.8 *This standard does not purport to address all of the safety concerns, if any, associated with its use. It is the responsibility of the user of this standard to establish appropriate safety and health practices and determine the applicability of regulatory limitations prior to use.*

2. Referenced Documents

2.1 *ASTM Standards:*²

A 390 Specification for Zinc-Coated (Galvanized) Steel Poultry Fence Fabric (Hexagonal and Straight Line)

C 1186 Specification for Flat Non-Asbestos Fiber-Cement Sheets

C 1396/C 1396M Specification for Gypsum Board

D 4442 Test Methods for Direct Moisture Content Measurement of Wood and Wood-Base Materials

D 4444 Test Methods for Use and Calibration of Hand-Held Moisture Meters

E 69 Test Method for Combustible Properties of Treated Wood by the Fire-Tube Apparatus

E 136 Test Method for Behavior of Materials in a Vertical Tube Furnace at 750°C

E 160 Test Method for Combustible Properties of Treated Wood by the Crib Test³

E 162 Test Method for Surface Flammability of Materials Using a Radiant Heat Energy Source

E 176 Terminology of Fire Standards

E 286 Method of Test for Surface Flammability of Building Materials Using an 8-ft (2.44-m) Tunnel Furnace³

E 2231 Practice for Specimen Preparation and Mounting of Pipe and Duct Insulation Materials to Assess Surface Burning Characteristics

E 2404 Practice for Specimen Preparation and Mounting of Paper or Vinyl Wall or Ceiling Coverings to Assess Surface

¹ This test method is under the jurisdiction of ASTM Committee E05 on Fire Standards and is the direct responsibility of Subcommittee E05.22 on Surface Burning.

Current edition approved Nov. 1, 2006. Published December 2006. Originally approved in 1950. Last previous edition approved in 2006 as E 84 – 06.

² For referenced ASTM standards, visit the ASTM website, www.astm.org, or contact ASTM Customer Service at service@astm.org. For *Annual Book of ASTM Standards* volume information, refer to the standard's Document Summary page on the ASTM website.

³ Withdrawn.

Burning Characteristics

3. Terminology

3.1 Definitions—For definitions of terms used in this test method refer to Terminology E 176. The term flame spread index from Terminology E 176 is of particular interest to this standard and is defined in 3.1.1.

3.1.1 flame spread index, *n*—a number or classification indicating a comparative measure derived from observations made during the progress of the boundary of a zone of flame under defined test conditions.

3.2 Definitions of Terms Specific to This Standard:

3.2.1 smoke developed index, *n*—a number or classification indicating a comparative measure derived from smoke obscuration data collected during the test for surface burning characteristics.

3.2.2 surface flame spread, *n*—the propagation of a flame away from the source of ignition across the surface of the specimen.

4. Significance and Use

4.1 This test method is intended to provide only comparative measurements of surface flame spread and smoke density measurements with that of select grade red oak and fiber-cement board surfaces under the specific fire exposure conditions described herein.

4.2 This test method exposes a nominal 24-ft (7.32-m) long by 20-in. (508-mm) wide specimen to a controlled air flow and flaming fire exposure adjusted to spread the flame along the entire length of the select grade red oak specimen in 5½ min.

4.3 This test method does not provide for the following:

4.3.1 Measurement of heat transmission through the tested surface.

4.3.2 The effect of aggravated flame spread behavior of an assembly resulting from the proximity of combustible walls and ceilings.

4.3.3 Classifying or defining a material as noncombustible, by means of a flame spread index by itself.

5. Apparatus

5.1 Fire Test Chamber—See Figs. 1-5.

5.1.1 The fire test chamber is a rectangular horizontal duct with a removable lid. The inside dimensions are as follows:

Width:	17 ¾ ± ¼ in. (451 ± 6.3 mm) measured between the top ledges along the side walls, and 17 ⅝ ± ⅜ in. (448 ± 10 mm) at all other points.
Depth:	12 ± ½ in. (305 ± 13 mm) measured from the bottom of the test chamber to the top of the ledges on which the specimen is supported. This measurement includes the ½ in. (3.2 mm) thickness of the 1 ½ in. (38 mm) wide woven fiberglass gasket tape.
Length:	25 ft ± 3 in. (7.62 m ± 76 mm).

5.1.2 The sides and base of the chamber shall be lined with an insulating firebrick with the dimensions of 4 ½ in. by 9 in. by 2 ½ in. thick as illustrated in Fig. 2. The insulating firebrick shall have the following properties:

Maximum Recommended Temperature	2600°F (1424°C)
Bulk Density	50 ± 3 lb/ft³ (0.77 ± 0.046 g/cm³)
Thermal Conductivity at Mean Temperature of	Btu·in./hr·ft²·°F W/m·°C
400°F (205°C)	1.7 0.24
800°F (425°C)	1.9 0.27
1200°F (650°C)	2.2 0.32
1600°F (870°C)	2.6 0.37
2000°F (1095°C)	3.2 0.46
2400°F (1315°C)	3.9 0.56

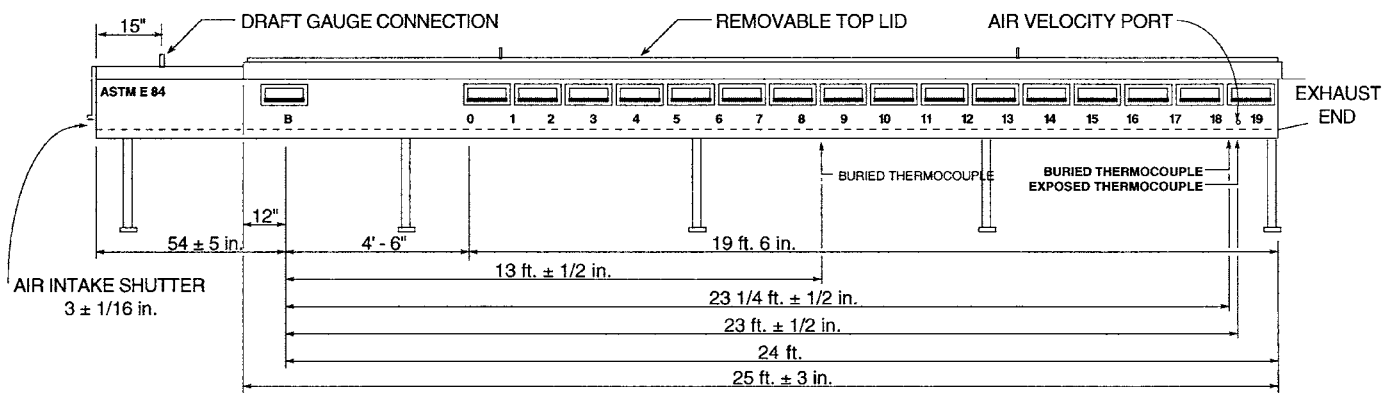

Inch-Pound Units	SI Units
3 ± 1/16 in.	76.2 ± 1.6 mm
12 in.	304.8 mm
15 in.	381 mm
54 ± 5 in.	1.37 m ± 127 mm
4 ft. 6 in.	1.37 m
19 ft. 6 in.	5.94 m
13 ft. ± 1/2 in.	3.96 m ± 12.7 mm
23 1/4 ft. ± 1/2 in.	7.1 m ± 12.7 mm
23 ft ± 1/2 in.	7.0 m ± 12.7 mm
24 ft.	7.32 m
25 ft. ± 3 in.	7.62 m ± 76.2 mm

FIG. 1 Test Furnace, Showing Some Critical Dimensions (Not a Construction Drawing)

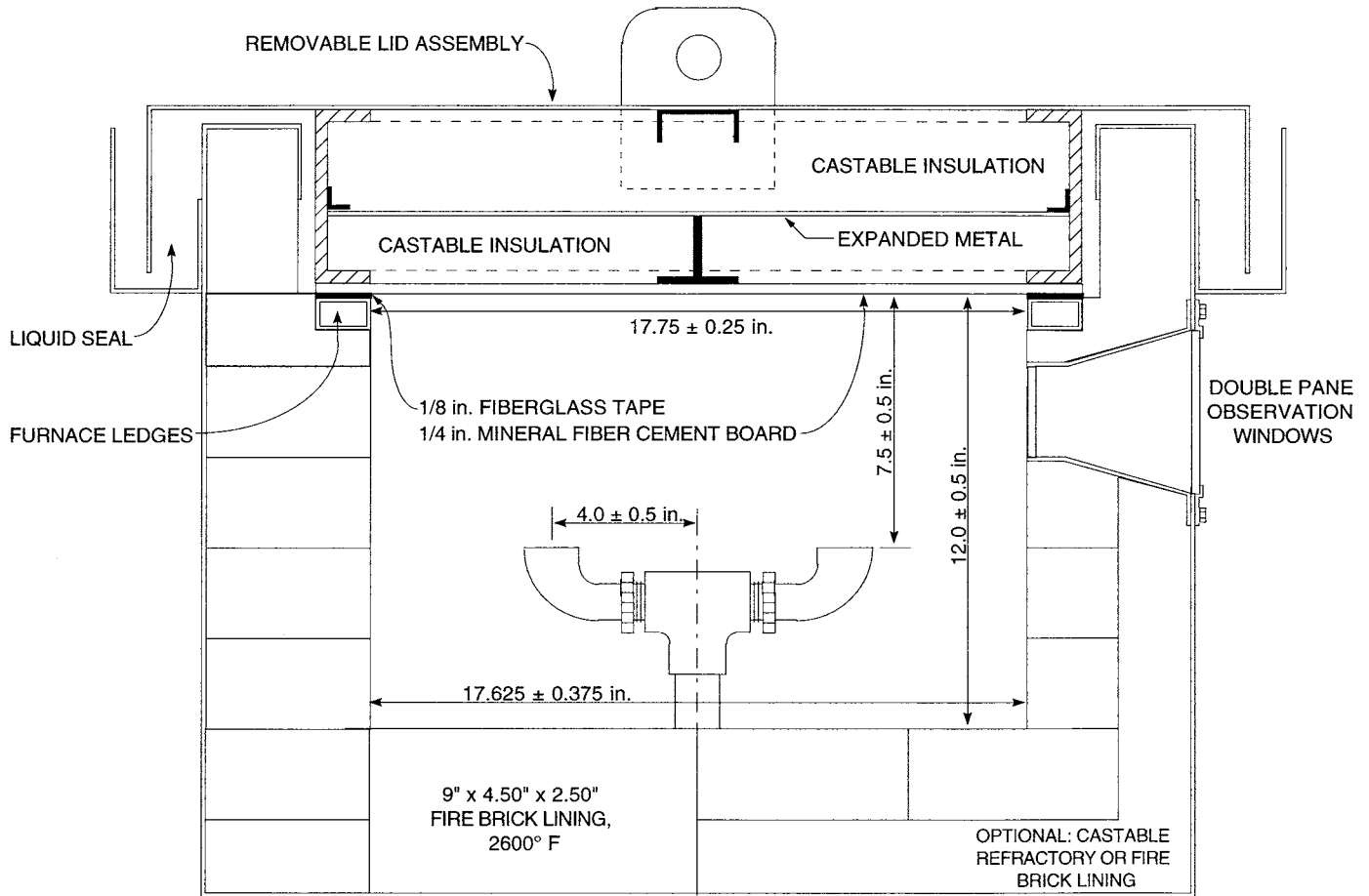

Inch-Pound Units	SI Units	Inch-Pound Units	SI Units	Inch-Pound Units	SI Units
4.0 ± 0.5 in.	101.6 ± 13 mm	17.625 ± 0.375 in.	447.7 ± 9.5 mm	9 in.	228.6 mm
7.5 ± 0.5 in.	190.5 ± 13 mm	2600°F	1427°C	4.5 in.	114.3 mm
12.0 ± 0.5 in.	317.5 ± 13 mm	1/8 in.	3.2 mm	2.5 in.	63.5 mm
17.75 ± 0.25 in.	450.9 ± 6.4 mm	1/4 in.	6.4 mm		

FIG. 2 Test Furnace Showing Critical Dimensions (Not a Construction Drawing)

5.1.3 One side of the chamber shall be provided with double observation windows⁴ with the inside pane flush mounted (see Fig. 2). Exposed inside glass shall be $2\frac{3}{4} \pm \frac{3}{8}$ by $11 + 1, -2$ in. (70 ± 10 by $279 + 25 - 50$ mm). The centerline of the exposed area of the inside glass shall be in the upper half of the furnace wall, with the upper edge not less than 2.5 in. (63 mm) below the furnace ledge. The window shall be located such that not less than 12 in. (305 mm) of the specimen width can be observed. Multiple windows shall be located along the tunnel so that the entire length of the test sample is observable from outside the fire chamber. The windows shall be pressure tight in accordance with 7.2 and 7.2.1.

5.1.4 The ledges shall be fabricated of structural materials⁵ capable of withstanding the abuse of continuous testing. The ledges shall be level with respect to the length and width of the chamber and each other. The ledges shall be maintained in a

state of repair commensurate with the frequency, volume, and severity of testing occurring at any time.

5.1.5 Lid:

5.1.5.1 The lid shall consist of a removable noncombustible metal and mineral composite structure as shown in Fig. 2 and of a size necessary to cover completely the fire test chamber and the test samples. The lid shall be maintained in an unwarped and flat condition. When in place, the lid shall be completely sealed to prevent air leakage into the fire test chamber during the test.

5.1.5.2 The lid shall be insulated with a minimal thickness of 2 in. (51 mm) castable insulation or mineral composite material having physical characteristics comparable to the following:

Maximum effective use temperature of at least:	1200°F (650°C)
Bulk density	21 lb/ft ³ (336 kg/m ³)
Thermal conductivity at 300 to 700°F (149 to 371°C)	0.50 to 0.71 Btu-in./h-ft ² ·°F (0.072 to 0.102 W/m·K)

5.1.5.3 The entire lid assembly shall be protected with flat sections of nominal 1/4-in. (6.3-mm) fiber-cement board meeting the properties of Annex A3. This protective board shall be

⁴ Heat-resistant glass, high-silica, 100 % silica glass, nominal 1/4-in. thick has been found suitable for the interior pane. Borosilicate glass, nominal 1/4-in. thick has been found suitable for the exterior pane.

⁵ High-temperature furnace refractory. Zirconium silicate, or water-cooled steel tubing have been found suitable for this purpose.

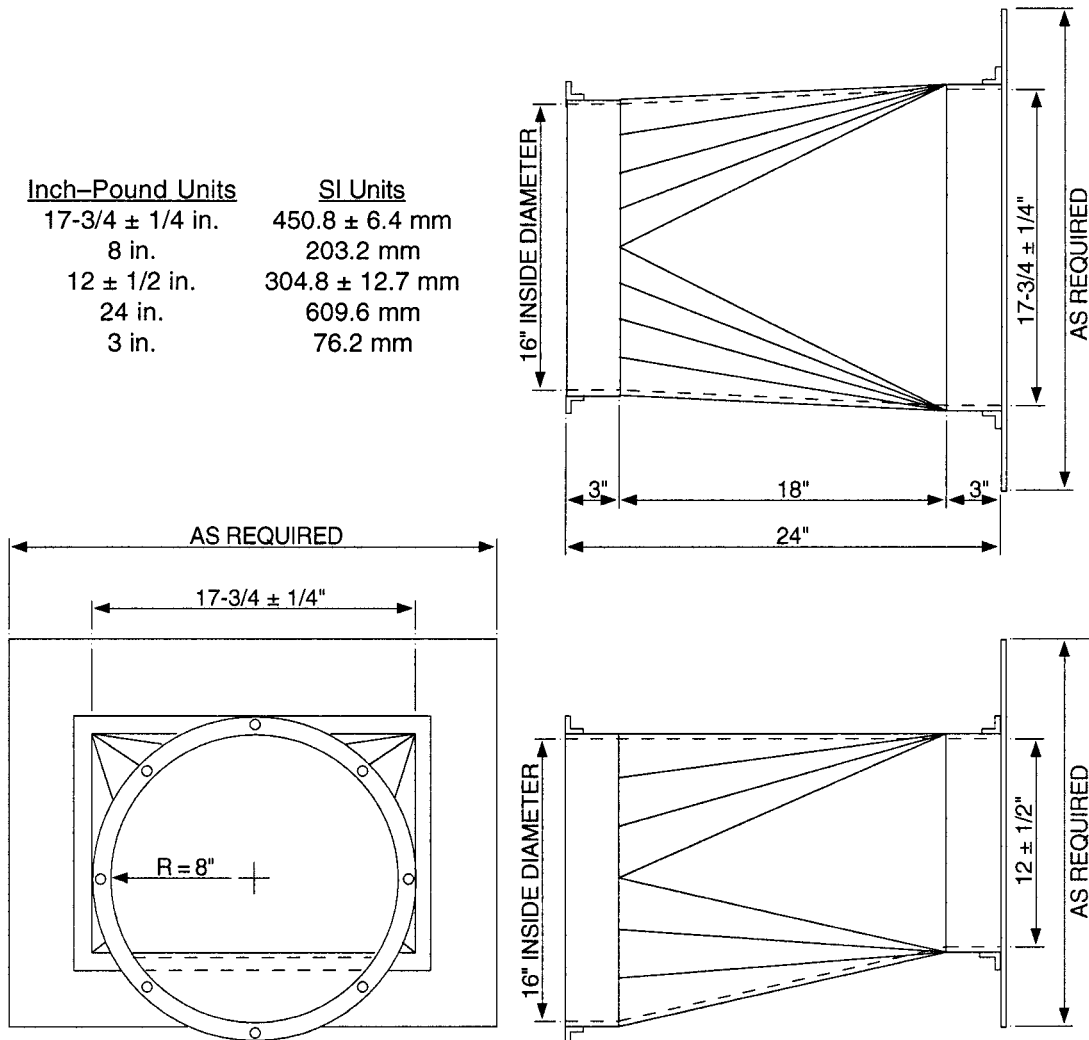

FIG. 3 Typical Exhaust End Transition (Not a Construction Drawing)

maintained in sound condition through continued replacement. The protective board is to be secured to the furnace lid or place on the back side of the test specimen.

5.1.6 Gas Burners:

5.1.6.1 One end of the test chamber shall be designated as the “fire end”. This fire end shall be provided with two gas burners delivering flames upward against the surface of the test sample (see Fig. 2). The burners shall be spaced 12 in. (305 mm) from the fire end of the test chamber, and 7 1/2 ± 1/2 in. (190 ± 13 mm) below the under surface of the test sample. Gas to the burners shall be provided through a single inlet pipe, distributed to each port burner through a tee-section. The outlet shall be a 3/4 in. NPT elbow. The plane of the port shall be parallel to the furnace floor, such that the gas is directed upward toward the specimen. Each port shall be positioned with its centerline 4 ± 1/2 in. (102 ± 13 mm) on each side of the centerline of the furnace so that the flame is distributed evenly over the width of the exposed specimen surface (see Fig. 2).

5.1.6.2 The controls used to assure constant flow of gas to the burners during period of use shall consist of a pressure

regulator, a gas meter calibrated to read in increments of not more than 0.1 ft³ (2.8 L), a manometer to indicate gas pressure in inches of water, a quick-acting gas shut-off valve, and a gas metering valve.

5.1.7 Air Intake:

5.1.7.1 An air intake shutter shall be located 54 ± 5 in. (1372 ± 127 mm) upstream of the burner, as measured from the burner centerline to the outside surface of the shutter (see Fig. 1). The air intake is to be fitted with a vertically sliding shutter extending the entire width of the test chamber. The shutter shall be positioned so as to provide an air inlet port 3 ± 1/16 in. (76 ± 2 mm) high measured from the floor level of the test chamber at the air intake point.

5.1.7.2 To provide air turbulence for proper combustion, turbulence baffling shall be provided by positioning six refractory firebricks (as defined in 5.1.2) along the side walls of the chamber. With the long dimension vertical, 4 1/2 in. (114-mm) dimension along the wall, place the bricks as follows from the centerline of the burner ports:

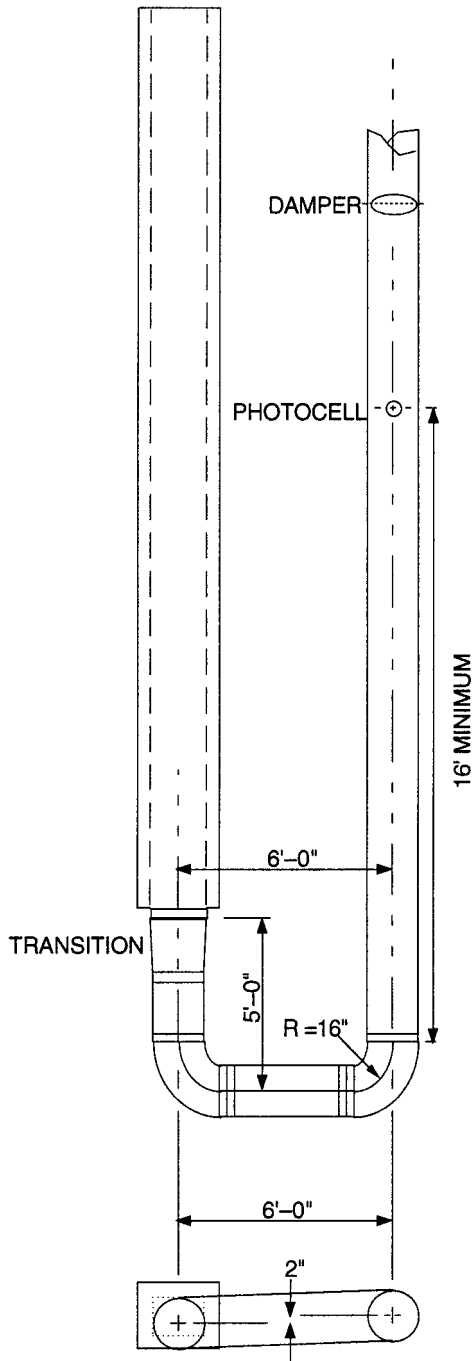

INCH-POUND UNITS	SI UNITS
16 in.	406.4 mm
2 in.	50.8 mm
5 ft.	1.52 m
6 ft.	1.83 m
16 - 40 ft.	4.88 - 12.2 m

FIG. 4 Plan View—Typical Duct System (Not a Construction Drawing)

On the window side at 7, 12, and $20 \pm \frac{1}{2}$ ft (2.1, 3.7, and 6.1 ± 0.2 m)
 On the opposite side at $4 \frac{1}{2}$, $9 \frac{1}{2}$, and $16 \pm \frac{1}{2}$ ft (1.3, 2.9, and 4.9 ± 0.2 m)

5.1.7.3 The movement of air shall be by an induced draft system having a total draft capacity of at least 0.15 in. (3.8

mm) water column with the sample in place, the shutter at the fire end open the normal $3 \pm \frac{1}{16}$ in. (76 ± 2 mm), and the damper in the wide open position. A draft gage tap to indicate static pressure shall be inserted through the top at the midwidth of the tunnel, 1 ± 0.5 in. (25 ± 12 mm) below the ceiling, 15 ± 0.5 in. (381 ± 12 mm) downstream from the inlet shutter (see Fig. 1).

5.1.8 Exhaust End:

5.1.8.1 The other end of the test chamber is designated as the exhaust end. The exhaust end shall be fitted with a gradual rectangular-to-round transition piece, not less than 20 in. (508 mm) in length, with a cross-sectional area of not less than 200 in.² (1290 cm²) at any point (see Fig. 3).

5.1.8.2 The transition piece shall in turn be fitted to a 16 in. (406 mm) diameter duct pipe. A typical duct system shown in Fig. 4 contains two 90° elbows (see Fig. 5) with the exhaust duct running beside the fire test chamber. In order to comply with this typical design, the vertical centerline of the exhaust duct system is identical to that of the fire test chamber.

5.1.8.3 The exhaust duct is to be insulated with at least 2 in. (51 mm) of high temperature mineral composition material from the exhaust end of the fire chamber to the photometer location.

5.1.8.4 An exhaust fan shall be installed at the end of the exhaust duct. The air flow shall be controlled as specified in 5.1.11.

5.1.8.5 An alternative exhaust duct layout design shall demonstrate equivalency by meeting the requirements specified in Section 7.

5.1.9 Photometer System:

5.1.9.1 A photometer system consisting of a lamp⁶ and photocell⁷ shall be mounted on a horizontal section of the 16-in. (406-mm) diameter vent pipe at a point where it will be preceded by a straight run of pipe (at least 12 diameters or 16 ft (4.88 m) and not more than 30 diameters or 40 ft (12.19 m) from the vent end of the chamber, and with the light beam directed upward along the vertical axis of the vent pipe. The vent pipe shall be insulated with at least 2 in. (51 mm) of high-temperature mineral composition material, from the vent end of the chamber to the photometer location. The photoelectric cell of which the output is directly proportional to the amount of light received shall be mounted over the light source and connected to a recording device having a minimum operating chart width of 5 in. (127 mm) with an accuracy within $\pm 1\%$ of full scale, for indicating changes in the attenuation of incident light by the passing smoke, particulate, and other effluent. The distance between the light source lens and the photocell lens shall be 36 ± 4 in. (914 ± 102 mm). The

⁶ The sole source of supply of the apparatus known to the committee at this time is 12-V sealed beam, clear lens, auto spot lamp, No. 4405, from General Electric, Nela Park, OH. If you are aware of alternative suppliers, please provide this information to ASTM Headquarters. Your comments will receive careful consideration at a meeting of the responsible technical committee, ¹ which you may attend.

⁷ The sole source of supply of the apparatus known to the committee at this time is No. 856BB from Weston Instruments, Wauconda, IL. If you are aware of alternative suppliers, please provide this information to ASTM Headquarters. Your comments will receive careful consideration at a meeting of the responsible technical committee, ¹ which you may attend.

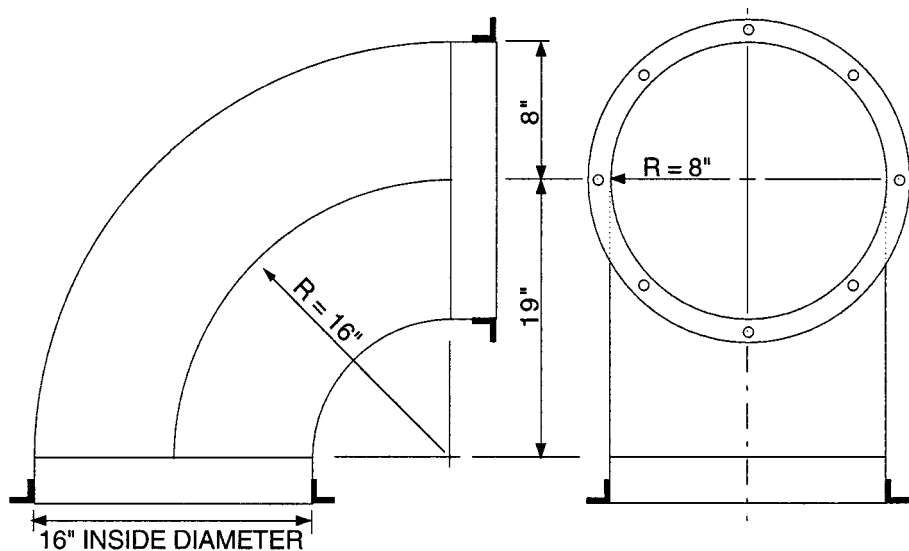

<u>Inch-Pound Units</u>	<u>SI Units</u>
16 in.	406.4 mm
8 in.	203.2 mm
19 in.	482.6 mm

FIG. 5 Typical Duct Elbow (Not a Construction Drawing)

cylindrical light beam shall pass through 3-in. (76-mm) diameter openings at the top and bottom of the 16-in. diameter duct, with the resultant light beam centered on the photocell.

5.1.9.2 Linearity of the photometer system shall be verified periodically by interrupting the light beam with calibrated neutral density filters. The filters shall cover the full range of the recording instrument. Transmittance values measured by the photometer, using neutral density filters, shall be within $\pm 3\%$ of the calibrated value for each filter.

5.1.10 *Draft Regulating Device:*

5.1.10.1 An automatically controlled damper to regulate the draft pressure shall be installed in the vent pipe down-stream of the smoke-indicating attachment. The damper shall be provided with a manual override.

5.1.10.2 Other manual or automatic draft regulation devices, or both, are allowed to be incorporated to help maintain fan characterization and air-flow control throughout the test.

5.1.11 *Thermocouples:*

5.1.11.1 A No. 18 Awg (1.02-mm) thermocouple, with $\frac{3}{8} \pm \frac{1}{8}$ in. (9.5 ± 3.2 mm) of the junction exposed in the air, shall be inserted through the floor of the test chamber so that the tip is $1 \pm \frac{1}{32}$ in. (25.4 ± 0.8 mm) below the top surface of the gasketing tape and $23 \text{ ft} \pm \frac{1}{2}$ in. ($7.0 \text{ m} \pm 13$ mm) from the centerline of the burner ports at the center of its width.

5.1.11.2 Two No. 18 Awg (1.02 mm) thermocouples are embedded below the floor surface of the test chamber. These thermocouples shall be mounted at distances of $13 \text{ ft} \pm \frac{1}{2}$ in. ($3.96 \text{ m} \pm 13$ mm) and $23 \frac{1}{4} \text{ ft} \pm \frac{1}{2}$ in. ($7.09 \text{ m} \pm 13$ mm) measured from the centerline of the burner ports. The thermocouples shall be inserted from below the fire test chamber through the firebrick until the tip of the thermocouple is $\frac{1}{8} \pm \frac{1}{32}$ in. (3.2 ± 0.8 mm) below the floor surface. The tip of the

thermocouples shall be covered with refractory or portland cement, carefully dried to avoid cracking.

6. Test Specimens

6.1 Specimens shall be representative of the materials which the test is intended to examine. The report shall include information on the composition needed for identification of the test specimen as described in 11.1.1.

6.2 The specimen shall be provided in one of two ways: (1) a continuous, unbroken length; (2) sections that will be joined or butted end-to-end.

6.3 The size of the test specimen shall be:

Width: between 20 and 24 in. (508 and 610 mm)

Length: 24 ft + 12 in. — 6 in.

Thickness: maximum 4 in. (101 mm).

NOTE 1—The test apparatus is not designed for testing at thicknesses greater than 4 in. (101 mm), but has the ability to be modified if required. This is accomplished through (a) modifications to the test apparatus lid to maintain an airtight seal, and (b) the introduction, usually of additional sample/lid supports above the test apparatus ledges. Due to the composition of some materials, test results obtained at a thickness greater than 4 in. (101 mm) will potentially vary from results of a test on the same material tested at a thickness of 4 in. (101 mm) or less.

6.4 The test specimen shall be conditioned to a constant weight at a temperature of $73.4 \pm 5^\circ\text{F}$ ($23 \pm 2.8^\circ\text{C}$) and at a relative humidity of $50 \pm 5\%$.

6.5 The upstream end of the fire test chamber shall be filled with a $14 \pm \frac{1}{8}$ —in. (356 ± 3 mm) length of uncoated 16-gauge (0.053 to 0.060 in.) steel plate positioned on the specimen mounting ledge in front of and under the leading edge of the specimen.

6.6 When the overall length of the test specimen exceeds 24 ft. (7.32 m), butt one end of the test specimen against the exhaust end of the fire test chamber and continue the installation of the specimen toward the gas burner.

6.7 When the overall length of the test specimen is 24 ft. (7.32 m) or less, provide a 1 in. (25 mm) overlap of the steel plate at the upstream end with one end of the test specimen and continue the installation of the specimen toward the exhaust end.

6.8 In addition to the above provisions, Practice E 2231 shall be used for preparing and mounting pipe and duct insulation materials, and Practice E 2404 shall be used for preparing and mounting paper wall and ceiling covering materials and vinyl wall and ceiling covering materials. For all other products, guidance on mounting methods is provided in Appendix X1.

7. Calibration

7.1 Place a nominal ¼-in. (6.3-mm) fiber-cement board meeting the properties of Annex A3 on the ledge of the furnace chamber. Place the removable lid of the test chamber in position.

7.2 With the ¼-in. (6.3-mm) fiber-cement board in position on top of the ledge of the furnace chamber and with the removable lid in place, establish a draft to produce a 0.15-in. (3.8-mm) water-column reading on the draft manometer, with the fire-end shutter open $3 \pm \frac{1}{16}$ in. (76 ± 1.5 mm), by manually setting the damper as a characterization of fan performance. Then close and seal the fire-end shutter, without changing the damper position. The manometer reading shall increase to at least 0.375 in. (9.53 mm), indicating that no excessive air leakage exists.

7.2.1 In addition, conduct a supplemental leakage test periodically with the tunnel sealed from the inlet end to beyond the photometer system, by placing a smoke bomb in the chamber. Ignite the bomb and pressurize the chamber to 0.375 ± 0.125 in. (9.53 ± 3.18 mm) water column. Seal all points of leakage observed in the form of escaping smoke particles.

7.3 Establish a draft reading within the range 0.055 to 0.100 in. (1.40 to 2.54 mm) water column. The required draft gage reading will be maintained throughout the test by the automatically controlled damper. Record the air velocity at seven points, 23 ft from the centerline of the burner ports, $6 \pm \frac{1}{4}$ in. (168 ± 7 mm) below the plane of the specimen mounting ledge. Determine these seven points by dividing the width of the tunnel into seven equal sections and recording the velocity at the geometrical center of each section. During the measurement of velocity, remove the turbulence bricks (see 4.3) and the exposed 23-ft thermocouple and place 24-in. (670-mm) long straightening vanes between 16 and 18 ft (4.88 and 5.49 m) from the burner. The straightening vanes shall divide the furnace cross section into nine uniform sections. Determine the velocity with furnace air temperature at $73.4 \pm 5^\circ\text{F}$ ($23 \pm 2.8^\circ\text{C}$), using a velocity transducer. The velocity, determined as the arithmetic average of the seven readings, shall be 240 ± 5 ft (73.2 ± 1.4 m)/min.

7.3.1 The following alternative to the velocity transducer equipment and method of determining the tunnel air velocity has been found suitable: A 4-in.-diameter low-speed rotary

vane anemometer, having a resolution of 1 ft./min. with an accuracy of $\pm 2\%$, is attached to the steel stand and placed in the tunnel 22.5 ft downstream of the burners. Three trials shall be conducted and their values averaged. The average is rounded to the nearest unit. The centerline of the vane anemometer shall be aligned with the vertical centerline of the tunnel by placing it on the steel stand. Trial 1 is run with the vane edge 1 in. from the non-window wall; Trial 2 is with the center axis at the tunnel center point; and Trial 3 is run with the vane edge 1 in. from the window wall.

7.4 The room in which the test chamber is located shall have provision for a free inflow of air during test to maintain the room at atmospheric pressure during the entire test run. Maintain the air supply at a temperature of $73.4 \pm 5^\circ\text{F}$ ($23 \pm 2.8^\circ\text{C}$) and a relative humidity of $50 \pm 5\%$.

7.5 Supply the fire test chamber with natural (city) or methane (bottled) gas fuel of uniform quality with a heating value of nominally 1000 Btu/ft³ (37.3 MJ/m³). Adjust the gas supply initially at approximately 5000 Btu (5.3 MJ)/min. Record the gas pressure, the pressure differential across the orifice plate, and the volume of gas used in each test. If a temperature- and pressure-compensating mass flowmeter is utilized, record only the volume of gas used. Unless otherwise corrected for, when bottled methane is employed, insert a length of coiled copper tubing into the gas line between the supply and metering connection to compensate for possible errors in the flow indicated due to reductions in gas temperature associated with the pressure drop and expansion across the regulator. With the draft and gas supply adjusted as indicated in 7.3 and 7.4, the test flame shall extend downstream to a distance of 4½ ft (1.37 m) over the specimen surface, with negligible upstream coverage.

7.6 Preheat the test chamber with the ¼-in. (6.3-mm) fiber-cement board and the removable lid in place and with the fuel supply adjusted to the required flow. Continue the preheating until the temperature indicated by the floor thermocouple at 23¼ ft (7.09 m) reaches $150 \pm 5^\circ\text{F}$ ($66 \pm 2.8^\circ\text{C}$). During the preheat test, record the temperatures indicated by the thermocouple at the vent end of the test chamber at intervals not longer than 15 s and compare these readings to the preheat temperature shown in the time-temperature curve in Fig. 3. This preheating is for the purpose of establishing the conditions that will exist following successive tests and for indicating the control of the heat input into the test chamber. If appreciable variation from the temperatures shown in the representative preheat curve is observed, suitable adjustments in the fuel supply may be necessary based on red oak calibration tests.

7.7 Allow the furnace to cool after each test. When the floor thermocouple at 13 ft (3.96 m) shows a temperature of $105 \pm 5^\circ\text{F}$ ($40.5 \pm 2.8^\circ\text{C}$), place the next specimen in position for test.

7.8 With the test equipment adjusted and conditioned as described in 7.2, 7.3, 7.4, and 7.6, make a test or series of tests, using nominal 2³/₃₂-in. (18.3-mm) select-grade red oak flooring as a sample. The red oak decks are to be constructed and conditioned as specified in Annex A1 and Annex A2. Make observations at distance intervals not in excess of 2 ft (0.6 m) and time intervals not in excess of 30 s, and record the time

when the flame reaches the end of the specimen 19½ ft (5.94 m) from the end of the ignition fire. The end of the ignition fire shall be considered as being 4½ ft (1.37 m) from the burners. The flame shall reach the end point in 5½ min ± 15 s. Automatically record the temperatures measured by the thermocouple near the vent end at least every 15 s. Automatically record the photoelectric cell output immediately prior to the test and at least every 15 s during the test.

7.8.1 Another means of judging when the flame has reached the end point is when the exposed thermocouple at 23 ft registers a temperature of 980°F (527°C).

7.9 Plot the flame spread distance, temperature, and change in photoelectric cell readings separately on suitable coordinate paper. Figs. 4-6 are representative curves for red oak flame spread distance, time-temperature development, and smoke density, respectively. Flame spread distance shall be determined as the observed distance minus 4½ ft (1.37 m).

7.10 Following the calibration tests for red oak, conduct a similar test or tests on samples of ¼-in. (6.3-mm) fiber-cement board. These results shall be considered as representing an index of 0. Plot the temperature readings separately on suitable coordinate paper. Fig. 7 is a representative curve for time-temperature development for fiber-cement board.

7.11 A calibration for red oak and for fiber-cement board shall be performed after major repairs, such as re-bricking, have been made. If there have been no major repairs, a new calibration for both red oak and fiber-cement board shall be conducted after 200 tests, or every 12 months, whichever comes first.

7.12 The red oak flame spread calibration data shall be used to confirm performance indicated in 7.8, that the flame reaches the end of the specimen at a time no less than 5 min 15 s and no more than 5 min 45 s from the start of the test. In the event that the flame reaches the end of the specimen outside these time limits, make adjustments and recalibrate until the correct time is achieved.

7.13 Add the data from the new smoke calibration to a data set containing the last four calibrations in order to maintain a running average of at least five calibrations. This average of smoke-developed index (SDI) data shall provide the calibration data to be used to adjust the settings for the equipment and to establish areas for calculation of the SDI. When fewer than five calibrations have been performed on new equipment, average the available number of calibrations to achieve the running average.

8. Procedure

8.1 With the furnace draft operating, place the test specimen on the test chamber ledges that have been completely covered

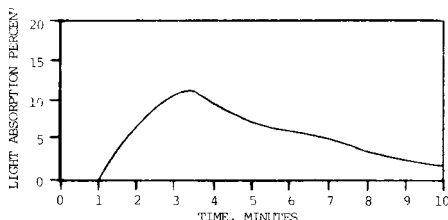

FIG. 6 Representative Time-Absorption Curve for Smoke Density of Red Oak

with nominal ⅛-in. (3.2-mm) thick by 1½-in. (38-mm) wide woven gasketing tape. Place the specimen as quickly as is practical. Place the removable top in position over the specimen.

8.2 Keep the completely mounted specimen in position in the chamber with the furnace draft operating for 120 ± 15 s prior to the application of the test flame.

8.3 Ignite the burner gas. Observe and record the distance and time of maximum flame front travel with the room darkened. Continue the test for a 10-min period. Termination of the test prior to 10 min is permitted if the specimen is completely consumed in the fire area and no further progressive burning is evident and the photoelectric cell reading has returned to the baseline.

8.4 Record the photoelectric cell output immediately prior to the test and at least every 15 s during the test.

8.5 Record the gas pressure, the pressure differential across the orifice plate, and the volume of gas used in each test. If a temperature- and pressure-compensating mass flowmeter device is used to monitor the gas flow, record only the volume of gas.

8.6 When the test is ended, shut off the gas supply, observe smoldering and other conditions within the test duct, and remove the specimen for further examination.

8.7 Plot the flame spread distance, temperature, and change in photoelectric cell readings separately on the same type of coordinate paper as used in 7.9 for use in determining the flame-spread and smoke-developed indexes as outlined in Section 9. Flame front advancement shall be recorded at the time of occurrence or at least every 30 s if no advancement is noted. Flame spread distance shall be determined as the observed distance minus 4½ ft (1.37 m).

9. Interpretation of Results

9.1 The flame spread index (FSI) shall be the value, determined as follows, rounded to the nearest multiple of five.

9.1.1 In plotting the flame spread distance-time relationship, all progressive flaming as previously recorded shall be included at the time of occurrence. A straight line shall be used to connect successive points. The total area (A_T) under the flame spread distance-time plot shall be determined by ignoring any flame front recession. For example, in Fig. 8 the flame spreads 10 ft (3.05 m) in 2½ min and then recedes. The area is calculated as if the flame had spread to 10 ft in 2½ min and then remained at 10 ft for the remainder of the test or until the flame front again passed 10 ft. This is shown by the dashed line in Fig. 8. The area (A_T) used for calculating the flame spread index is the sum of areas A_1 and A_2 in Fig. 8.

9.1.2 If this total area (A_T) is less than or equal to 97.5 ft-min, the flame spread index shall be 0.515 times the total area ($FSI = 0.515 A_T$).

9.1.3 If the total area (A_T) is greater than 97.5 ft-min, the flame spread index shall be 4900, divided by the difference of 195 minus the total area (A_T). ($FSI = 4900/(195 - A_T)$).

9.2 The test results for smoke shall be plotted, using the same coordinates as in 7.9. The area under the curve shall be divided by the area under the curve for red oak, multiplied by 100, and rounded to the nearest multiple of five to establish a numerical smoke-developed index. The performance of the

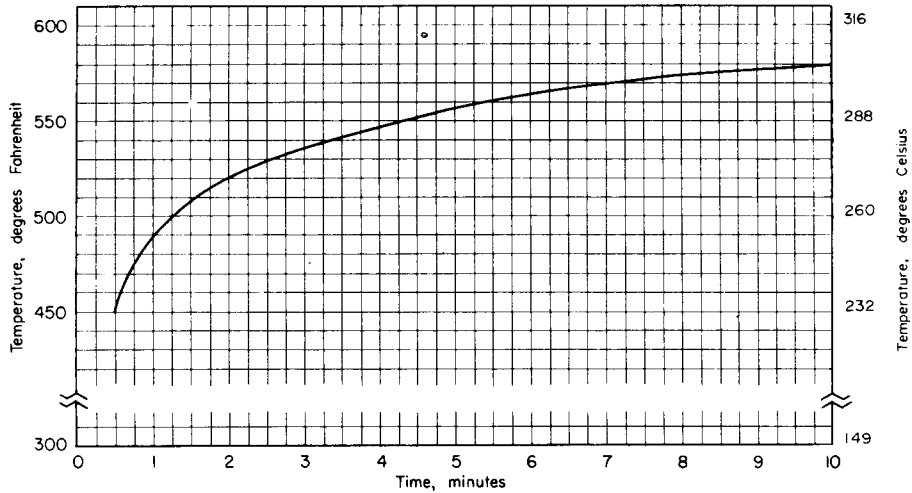

FIG. 7 Representative Time-Temperature Curve for Fuel Contribution of Fiber-Cement Board

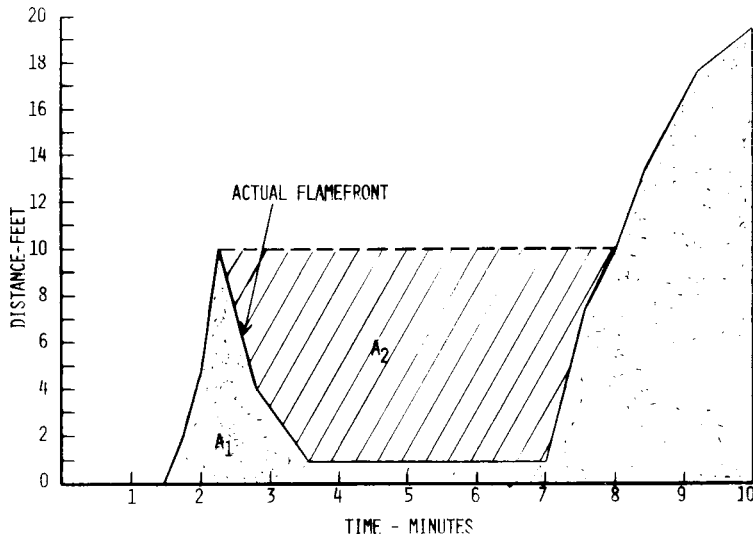

FIG. 8 Example of Time-Distance Relationship with Flame Front Recession (Total Area, $A_T = A_1 + A_2$)

material is compared with that of fiber-cement board and select grade red oak flooring, which have been arbitrarily established as 0 and 100, respectively. For smoke-developed indexes 200 or more, the calculated value shall be rounded to the nearest 50 points.

NOTE 2—Allowance should be made for accumulation of soot and dust on the photoelectric cell during the test by establishing a revised base line. The revised base line shall be a straight line drawn from the zero point (point on base line where incipient light attenuation occurs) to the point established after the sample has been removed.

10. Analysis of Products of Combustion

10.1 Samples for combustion product analysis, when analysis is requested, shall be taken downstream from the photometer, or shall consist of not more than 1 % of the total flow. Analysis of the products of combustion is not required in this test method.

11. Report

11.1 Report the following information:

11.1.1 Description of the material being tested, including its composition or generic identification, thickness, and any relevant additional details,

11.1.2 Test results as calculated in Section 9,

11.1.3 Details of the method used in placing the specimen in the chamber, to include the following:

11.1.3.1 A statement whether a continuous or sectioned specimen is used,

11.1.3.2 A description of the number of sections and their sizes, when the specimen consists of sections joined end-to-end,

11.1.3.3 The mounting method employed,

11.1.3.4 The method of placement of the cement board protecting the furnace lid assembly.

11.1.4 Observations of the burning characteristics of the specimen during test exposure, such as delamination, sagging, shrinkage, fallout, etc., and

11.1.5 Graphical plots of flame spread and smoke developed data.

12. Precision and Bias ⁸

12.1 *Precision*—A series of interlaboratory tests for this test method was run using eleven laboratories and six materials. Four replicates of each material were tested. The complete results have been placed on file at ASTM Headquarters as a Research Project entitled “Interlaboratory Test Study on ASTM E84, Standard Test Method for Surface Burning Characteristics of Building Materials.” Data was calculated in accordance with Practice E 691 and ISO 5725.

12.2 Even though Test Method E 84 provides measurement of a Flame Spread Index and a Smoke Developed Index, only the Flame Spread Index is considered in this precision statement because the test series utilized a smoke measurement system that was a variation from that described in the test method. Data on precision of the smoke developed index is being worked on by Task Group No. 1 of Subcommittee E5.22 and will be included in a future revision of this test method.

12.3 Within-laboratory (repeatability) data is given in **Table 1**.

12.4 Between-laboratory (reproducibility) data is given in **Table 2**.

12.5 *Bias*—No information is presented on the bias of the procedure in this test method because correct values for fire-test-response characteristics of building materials can only

⁸ Supporting data have been filed at ASTM Headquarters and may be obtained by requesting PCN 33000014-31.

TABLE 1 Within-Laboratory (Repeatability) Precision Data

Material	Parameter—Flame Spread Index		
	Mean Value	Repeatability Standard Deviation, S_r	Relative Standard Deviation, %
Douglas Fir Plywood	91	15	16
Fire Retardant Treated Douglas Fir Plywood	17	3	17
Type X Gypsum Board	9	2	19
Rigid Polystyrene Foam	7	1	18
Rigid Polyurethane Foam	24	3	13
Composite Panel	17	2	12

TABLE 2 Between-Laboratory (Reproducibility) Precision Data

Material	Parameter—Flame Spread Index		
	Mean Value	Reproducibility Standard Deviation, S_R	Relative Standard Deviation, %
Douglas Fir Plywood	91	23	25
Fire Retardant Treated Douglas Fir Plywood	17	6	33
Type X Gypsum Board	9	3	36
Rigid Polystyrene Foam	7	4	60
Rigid Polyurethane Foam	24	5	23
Composite Panel	17	4	21

be defined in terms of a test method. Within this limitation, this test method has no known bias and can be accepted as a reference method.

13. Keywords

13.1 flame spread; flame spread index; smoke developed; smoke developed index; Steiner tunnel; surface burning characteristics; 25 ft tunnel; tunnel test

ANNEXES

(Mandatory Information)

A1. CONSTRUCTION GUIDELINES OF RED OAK DECKS

A1.1 Introduction

A1.1.1 General construction outline of the red oak decks is shown in **Fig. A1.1**.

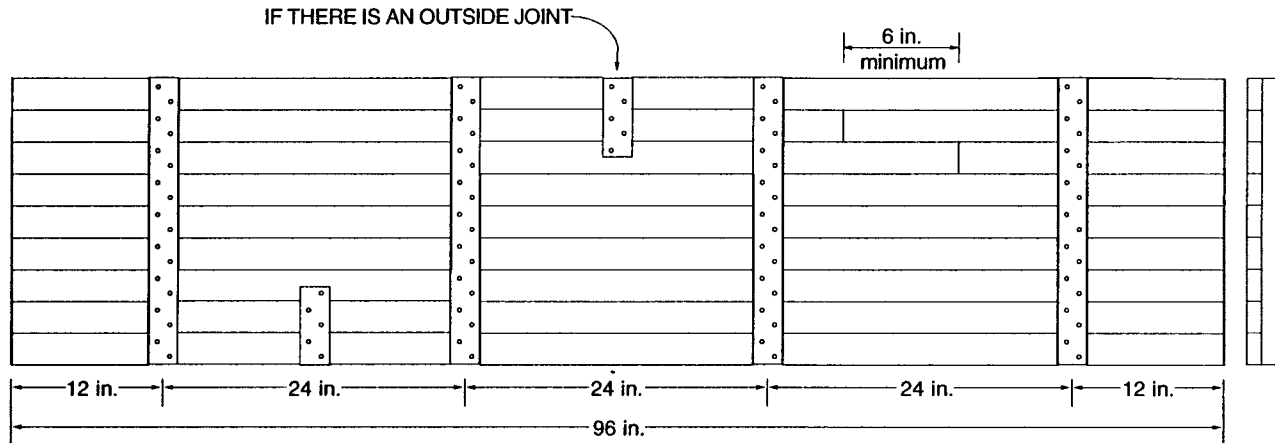

- Use 9 rows of red oak per deck.
- Batten strips are nominal 1 in. by 2 in. or 1 in. by 3 in.
- Use 4d cement coated nails or equivalent, two per red oak strip per batten.
- For outside edges, use longest red oak strips available. If shorter than 96 in., use 6 in. long batten strips.
- Do not use red oak strips less than 24 in. long on outside edge.
- Allow 6 in. minimum distance between other joints on adjacent red oak strips.
- While nailing, use cabinet clamps or other suitable means to ensure there are no cracks or gaps between the red oak strips in the deck surface.

Inch-Pound Units	SI Units
1 in.	25.4 mm
2 in.	50.8 mm
6 in.	152.4 mm
12 in.	304.8 mm
24 in.	609.6 mm
96 in.	2.44 m

FIG. A1.1 Red Oak Calibration Deck Construction

A2. PROCEDURE FOR DETERMINING MOISTURE CONTENT IN RED OAK

A2.1 Introduction

A2.1.1 This procedure shall be used for the determination of moisture content of the select-grade red oak calibration material. From trimmed sections of the calibration decks, prepare a minimum of six specimens $4 + \frac{1}{16} - 0$ inches ($100 + 2 - 0$ mm) long. The specimens shall be free from visible irregularities of knots, decay, reaction wood, and resin concentration. Place the trimmed sections adjacent to the calibration decks in a condi-

tioning atmosphere that will result in an average moisture content of $7 \pm 0.5\%$. Using either a conductance or dielectric-type meter (calibrated per Test Methods D 4444), monitor moisture content until the desired level is reached. Subject the trimmed sections only to the secondary oven-drying method (Method B) in Test Methods D 4442 for the final determination of moisture content.

A3. FIBER-CEMENT BOARD REQUIREMENTS

A3.1 Introduction:

A3.1.1 The fiber-cement board shall comply with Specification C 1186 Grade II, and the following additional properties:

- A3.1.1.1 Nominal thickness shall be $\frac{1}{4}$ in. (6.3 mm).
- A3.1.1.2 Density = 90 ± 10 lb/ft³ (1444 ± 160 kg/m³).

A3.1.1.3 Board shall be uncoated.

A3.1.1.4 Pass Test Method E 136.

A3.1.1.5 The board shall stay in-place during a 10-min. test.

A3.1.1.6 Shall be suitable for test sample adhesion.

X1. GUIDE TO MOUNTING METHODS

X1.1 Introduction

X1.1.1 Discussion:

X1.1.1.1 This guide has been compiled as an aid in selecting a method for mounting various building materials in the fire test chamber. These mountings are suggested for test method uniformity and convenience; they are not meant to imply restriction in the specific details of field installation.

X1.1.1.2 For some building materials none of the methods described may be applicable. In such cases, other means of support may have to be devised.

X1.1.1.3 These suggested mounting methods are grouped according to building materials to be tested which are broadly described either by usage or by form of the material.

X1.1.2 Support Pieces:

X1.1.2.1 Whenever fiber-cement board is specified as a backing in this appendix, the material shall be nominal 1/4" (6.3 mm) thick, meeting the properties of Annex A3.

X1.1.2.2 Whenever metal rods or bars are specified in this appendix as supports they should be:

- Steel rods, 1/4 in. (6.3 mm) diameter
- Steel bars, 3/16 by 2 in. (5 by 51 mm)

(a) The rods or bars should span the width of the tunnel. Rods should be placed approximately 2 in. (51 mm) from each end of each panel and at approximately 2-ft (0.6-m) intervals starting with the fire end of each panel.

(b) Bars are used instead of rods only when they are required to support the sample. The bars should be placed approximately 2 in. (51 mm) from each end of each panel and at approximately 2-ft (0.6-m) intervals starting with the fire end of each panel.

X1.1.2.3 Whenever netting is specified as a support in this appendix, the material shall be 20-gage, 2-in. (51-mm) hexagonal galvanized steel netting conforming to Specification A 390.

X1.1.3 Joints:

X1.1.3.1 Products that are normally installed adjoining themselves longitudinally are evaluated under this paragraph.

(a) Mounting methods should be considered for building products that normally incorporate joint details either in design or installation. A nonhomogenous product containing underly-

ing core (Note X1.1) material that may adversely affect the test results should be tested with a joint. This joint should be located longitudinally between the burners.

NOTE X1.1—Core is defined as: a central and often foundational part usually distinct from the enveloping part by a difference in nature (Webster's New Collegiate Dictionary).

(b) The surface burning behavior should be determined using the manufacturer's recommended joint detail.

(c) If a joint detail is not recommended by the manufacturer, the product should be tested both with a separation of 3/16 ± 1/16 in. (4.2 ± 1.5 mm) and with the edges in direct contact.

X1.2 Acoustical and Other Similar Panel Products Less Than 20 in. (508 mm)

X1.2.1 For acoustical materials and other similar panel products whose maximum dimension is less than 20 in. (508 mm), metal splines or wood furring strips and metal fasteners shall be used.

X1.2.2 Steel tee splines for mounting kerfed-acoustical tile shall be nominal 1/2-in. (13-mm) web by 3/4-in. (19-mm) flange, formed No. 24 MS gage sheet metal.

X1.2.3 Wood furring frames for mounting acoustical materials and other similar panel products less than 20 in. (508 mm) shall be nominal 1 by 2-in. (20 by 41-mm) wood furring joined with corrugated-metal fasteners. Use two frames as shown in Fig. X1.1.

X1.3 Adhesives

X1.3.1 To determine the surface burning characteristics of adhesives, they shall be mixed as specified in the manufacturer's instructions and shall be applied to fiber-cement board in the thickness or at the coverage rate recommended by the manufacturer. The adhesive application shall be cured prior to testing.

X1.4 Batt or Blanket-Type Insulating Materials

X1.4.1 Batt or blanket materials that do not have sufficient rigidity or strength to support themselves shall be supported by metal rods inserted through the material and positioned such that the bottom of the rod is approximately 1/4 in. (6.3 mm)

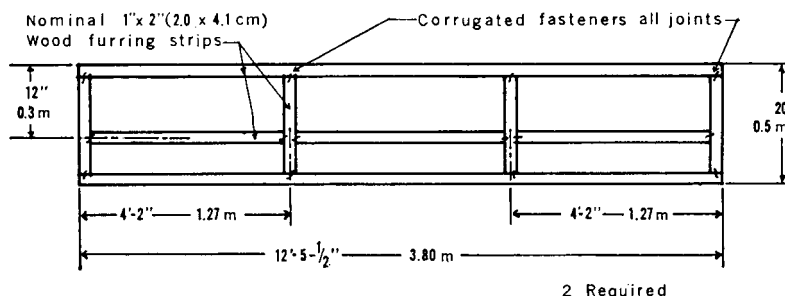

FIG. X1.1 Wood Frame for Acoustical Materials and Other Similar Panel Products Less Than 20 in. (508 mm)

from the surface to be exposed to the flame. It is recommended that batt or blanket materials less than 1 in. (25.4 mm) thick not be mounted for testing in this manner.

X1.5 Coating Materials, Cementitious Mixtures, and Sprayed Fibers

X1.5.1 Coating materials, cementitious mixtures, and sprayed fibers shall be mixed and applied to the substrate as specified in the manufacturer’s instructions at the thickness, coverage rate, or density recommended by the manufacturer.

X1.5.2 Materials intended for application to wood surfaces shall be applied to a substrate made of nominal 2³/₃₂ in. (18-mm) select grade, red oak flooring which is also used as the calibration material. Test decks placed end to end shall be used. Construct and condition in accordance with Annex A1 and Annex A2.

X1.5.3 Materials intended for application to particular combustible surfaces shall be applied to the specific surfaces for which they are intended.

X1.5.4 Materials intended for only field application to noncombustible surfaces shall be applied to 1/4-in. (6.3-mm) fiber-cement board.

X1.5.5 Since the nature of the substrate may significantly affect the performance of the fire retardant coating, an indication of the performance of a fire retardant coating can be determined by comparing the surface flammability of the coated substrate with that of the uncoated, specific substrate.

X1.6 Loose-Fill Insulation

X1.6.1 Loose-fill insulation shall be placed on galvanized-steel screening⁹ with approximate 3/64-in. (1.2-mm) openings supported on a test frame 20 in. (508 mm) wide by 2 in. (51 mm) deep, made from 2 by 3 by 3/16-in. (51 by 76 by 5-mm) steel angles. Three frames are required. See Fig. X1.2. The insulation shall be packed to the density specified by the manufacturer.

X1.7 Plastics

X1.7.1 The term plastics includes foams, reinforced panels, laminates, grids, and transparent or translucent sheets.

X1.7.2 When any plastic will remain in position in the tunnel during a fire test, no additional support will be required. Thermoplastic and other plastics that will not remain in place are to be supported in accordance with X1.1.2.2 and X1.1.2.3.

X1.8 Thin Membranes

X1.8.1 Single-layer membranes or thin laminates consisting of a limited number of similar or dissimilar layers not intended for adherence to another surface may be supported on poultry netting placed on steel rods in accordance with X1.1.2.2 and X1.1.2.3. Netting shall be 20-gage, 2-in. (51-mm) hexagonal galvanized steel poultry netting conforming to Specification A 390. If so tested, the specimen shall be additionally tested, bonded to a substrate representative of a field installation.

X1.9 Wall Coverings

X1.9.1 Whenever an adhesive is used to attach a wall covering, adhesive specified by the manufacturer shall be used in the test in a manner consistent with field practice.

X1.9.2 Mount wall coverings intended for application to either a noncombustible wall surface or to gypsum wallboard in accordance with X1.9.4. Wall covering tested over gypsum wallboard in accordance with X1.9.4 need not be retested over fiber-cement board.

X1.9.3 Mount wall coverings intended for application directly to a noncombustible wall surface to 1/4 in. (6.3 mm)-fiber-cement board.

X1.9.4 Mount wall coverings intended to be applied over gypsum wallboard to 5/8 in. (15.9 mm) Type X gypsum wallboard complying with Specification C 1396/C 1396M. There is no need to mount the gypsum wallboard on studs.

X1.9.5 Mount wall coverings intended for application over a combustible substrate to one representative of that substrate.

X1.9.6 Mount wall coverings not intended to be adhered directly to a wall surface, but hung or otherwise supported by framing or a track system, in a manner that is representative of their installation. Where this is not practical, support the sample on netting placed on metal rods as provided in X1.1.2.2 and X1.1.2.3.

X1.10 Mounting Method for Textile Materials

X1.10.1 When the surface burning characteristics of the material itself are required, specimens shall be mounted on fiber-cement board with high temperature bonding mortar. In the event the specimen cannot be adhered using high temperature bonding mortar, a two-part epoxy adhesive has been found

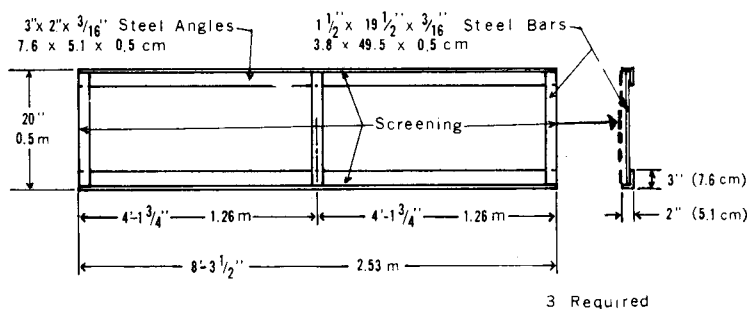

FIG. X1.2 Steel Frame for Loose Fill Materials

⁹ The use of galvanized steel screening normally lowers the flame spread index values obtained for some materials that are tested in this manner and, therefore, the results do not necessarily relate directly to values obtained for other materials mounted without galvanized steel screening.

to be a suitable alternative. The application shall be determined by a 3/32-in. (2.4-mm) notched trowel held at an 80 to 90° angle using a random pattern. The adhesive shall be applied only to the specimen back. The specimen shall then be placed on the smooth side of the fiber-cement board and rolled using a 100-lb (45.4-kg) roller (nominal 5-in. (127-mm) diameter, three 5-in. long sections placed end to end for a total length of 15 in. (381 mm). The prepared samples can be dead stacked overnight but should be transferred to separate storage racks until tested. Each sample shall be vacuumed prior to test.

X1.10.2 Due to the physical nature of some materials, neither the use of a 3/32-in. (2.4-mm) notched trowel nor that of a 100-lb (45.4-kg) roller is appropriate. In such instances, apply the adhesive using a 3/8-in. (9.5-mm) napped paint roller. Remove all wrinkles and air pockets, using pressure from a clean, dry 1/4-in. (6.4-mm) napped paint roller taking care not to force the adhesive into the specimen, or to stretch or physically deform the specimen. A suitable alternative for pressure application is a flat 12-in. (305-mm) brush with 1-in. (25.4-mm) nylon bristles.

X1.10.2.1 Due to the porosity or density of some materials, application of the adhesive using either the notched trowel or the 100-lb (45.4-kg) roller, or both, will force the adhesive into and through the specimen causing “bleed through.” In such instances, the flame spread and smoke developed indices obtained would not necessarily relate to indices obtained by testing without such influence.

X1.10.2.2 Due to the mechanical action of the trowel, severe stretching or physical deformation of some materials will occur, especially true with some knitted products. Deformation of a specimen results in a different area weight and density, and thereby influences the fuel load contributed by the specimen. In such instances, the flame spread and smoke developed indices obtained would not necessarily relate to indices obtained by testing without such influence.

X1.10.2.3 If, due to the physical nature of the material, it is not possible to apply the adhesive to the specimen back, apply the adhesive to the smooth side of the fiber-cement board and bond the specimen as directed in X1.10.1 or X1.10.2.

X1.10.3 Textile materials intended for application to walls or ceilings should be mounted in accordance with X1.9.

X2. DERIVATION OF FLAME SPREAD AREA FORMULAS APPEARING IN 8.1

X2.1 Introduction

X2.1.1 This appendix contains an abbreviated discussion of the derivations of the flame spread area formulas used to calculate the flame spread index in this test method. This appendix will show not only the derivations of the formulas, but will illustrate the relationship between this method of flame spread calculation and a previous method.

X2.1.2 In these calculations, it is assumed that the flame front never recedes. Hence, in Fig. 8 there is an imaginary line bounding the upper edge of area A₂.

distance-time plot is drawn. Lines OA, OA', and OA'' produce a family of areas ORA having a maximum possible area of 97.5 ft·min (1/2 by 10 min by 19.5 ft). These represent a steady progression of the flame front to a maximum distance at the end of the 10-min test.

X2.2.2 When the flame front spreads its maximum distance (19.5 ft) in 10 min, a formula used in Test Method E 84 would yield the following:

$$FSI = \frac{550}{t} = \frac{550}{10} = 55 \tag{X2.1}$$

X2.2 Formula 1—Constant

X2.2.1 In Fig. X2.1, an idealized straight-line flame spread

X2.2.3 Also, when the flame front is maximized at 19.5 ft in 10 min, the area in Fig. X2.1 ORA is maximized to 97.5 ft·min.

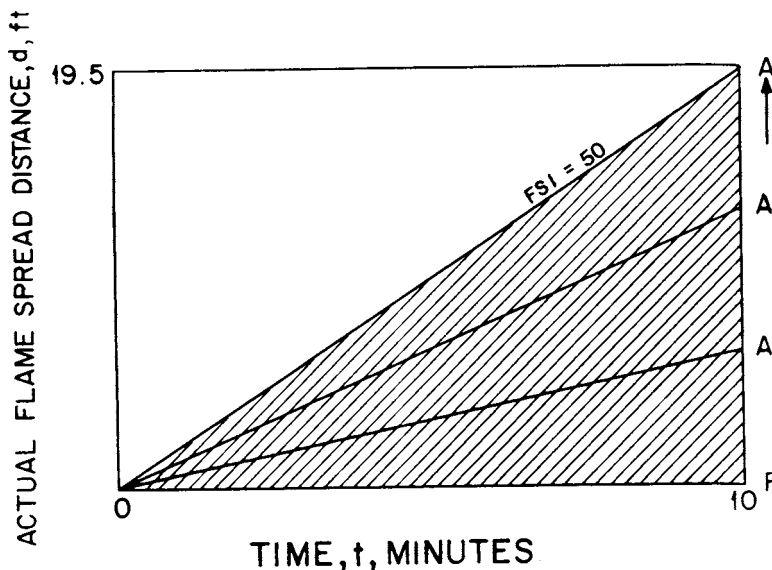

FIG. X2.1 Idealized Straight-Line Flame Spread Distance-Time Curve for Total Areas Less than or Equal to 97.5 min·ft

X2.2.4 To relate the current formula, which is of the straight line, origin intercept form, to the previous (Test Method E 84) formula, it is necessary to equate the two as follows:

$$FSI = \frac{550}{t} = KA \tag{X2.2}$$

where:

- K = proportionality constant for equations of the current formula's type, and
- A_T = total area under area ORA.
- If A_T = 97.5 ft·min at $t = 10$ min, then

$$FSI = \frac{550}{100} = K \times 97.5, \text{ and} \tag{X2.3}$$

$$K = \frac{550}{10 \times 97.5} = 0.564 \tag{X2.4}$$

X2.3 Formula 2—Constant

X2.3.1 In the idealized straight-line flame spread distance-time curve of Fig. X2.2, lines OI , OI' , and OI'' produce a family of trapezoidal areas $ORBI$ ranging from 97.5 to 195 ft·min (½ by 10 min by 19.5 ft to 10 min by 19.5 ft). This represents a flame front progression to the end of the specimen within the 10 min of the test. The area (A_T) of $ORBI$ may be expressed as follows:

$$\left(\frac{1}{2} \text{ by } 19.5 \text{ by } OR\right) + \left(\frac{1}{2} \text{ by } 19.5 \text{ by } (10-At)\right) \tag{X2.5}$$

which is equal to:

$$195 - 9.75 AI \tag{X2.6}$$

since OR is always 10 min.

X2.3.2 The triangular area OIA divided into a proportionality constant K will determine a relationship between flame spread indexes and the rate and distance of flame propagation. The total area available is 195 ft·min, hence area OIA is equal to $195 - ORBI$.

Thus, a new flame spread index formula may be derived as follows:

$$FSI = \frac{K}{OIA} = \frac{K}{195 - ORBI} = \frac{K}{195 - A_T} \tag{X2.7}$$

X2.3.3 To establish K , a relationship between the current and the previous Test Method E 84 formulas will be established at the red oak calibration point of 19.5 ft progression at 5.5 min as follows:

$$FSI = \frac{550}{t} = \frac{K}{195 - A_T} \tag{X2.8}$$

where:

- A_T = $195 - (9.75 (5.5)) = 141.38$ ft·min, and
- t = 5.5 min.

Thus:

$$FSI = \frac{550}{5.5} = \frac{K}{195 - 141.38}, \text{ or} \tag{X2.9}$$

$$K = \frac{550 \times (53.63)}{5.5} = 5363$$

X2.4 Formulas 1 and 2

X2.4.1 To account for the disproportionate increase which can occur in FSI values at the lower end of the index scale, for $K = 0.564$ in Formula 1 and 5363 in Formula 2, a further mathematical modification is made.

X2.4.2 In order to establish a relationship between the constants (K) in X2.2 and X2.3, it is necessary to consider the form of the basic formulae, which are as follows:

$$FSI = \frac{K_1}{195 - A_T} (A > K_2) \tag{X2.10}$$

$$FSI = K_3 A_T (A < K_2)$$

where:

- K_1 = $100 (195 - R)$,
- R = the area associated under the curve that is to be associated with an index of 100,
- K_2 = an arbitrary choice within the limits of 0 and 195, and

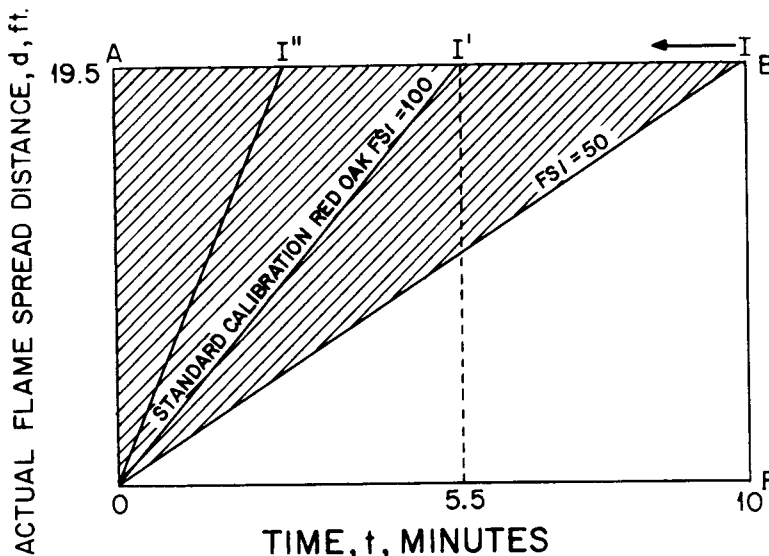

FIG. X2.2 Idealized Straight-Line Flame Spread Distance-Time Curve for Total Areas Greater than 97.5 min-ft

$$K_3 = K_1/(K_2[195 - K_2]).$$

X2.4.3 Choosing $K_2 = 195/2$ produces a minimum value of K_3 , that is, any other K_2 value will result in a higher K_3 value, and choosing R , the area under a red oak calibration plot, as a median value of 146, implies the following:

$$K_1 = 100(195 - 146) = 4900 \quad (\text{X2.11})$$

X2.4.4 Then using 97.5 as the value for K_2 , K_3 would be:

$$K_3 = 4900/(97.5 \times 97.5) = 0.515 \quad (\text{X2.12})$$

X2.4.5 Thus, the formula for flame spread index in 8.1.2 is as follows:

$$FSI = 0.515 A_T \quad (\text{X2.13})$$

X2.4.6 Thus, the formula for flame spread index in 8.1.3 is as follows:

$$FSI = \frac{4900}{195 - A_T} \quad (\text{X2.14})$$

X3. GUIDE TO HANDLING MULTIPLE TEST DATA

X3.1 Introduction

X3.1.1 The following is a recommended procedure for average flame spread index and smoke developed index results:

X3.2 Flame Spread Index (FSI)

X3.2.1 Average the individual calculated flame-spread values determined in accordance with 9.1, then round the average to the nearest multiple of 5 points. The rounded average is the FSI.

X3.3 Smoke Developed Index (SDI)-Average Smoke Value 200 or Under

X3.3.1 Average the individual calculated smoke developed values determined in accordance with 9.2. If the average is 200

or lower, round the average to the nearest multiple of 5 points. The rounded average is considered the SDI.

X3.4 Smoke Developed Index (SDI)-Average Smoke Value Over 200

X3.4.1 Average the individual calculated smoke developed values determined in accordance with 9.2. If the average is over 200, round the average to the nearest multiple of 50 points. The rounded average is the SDI.

X4. COMMENTARY

X4.1 Introduction

X4.1.1 This commentary has been prepared to provide the user of Test Method E 84 with background information, including literature references, on the development and use of this test method. It also provides the reader and user with the basis for the methods that have been used for deriving numerical flame spread indexes; an appreciation of the variability of the test; and comments on its application and limitations for testing selected types of materials.

X4.1.2 On Nov. 28, 1942, 490 people died in a fire in the Boston Coconut Grove Nightclub. On June 5, 1946, 61 persons died in the La Salle Street Hotel fire. On Dec. 7, 1946, a fire in the Wincoff Hotel in Atlanta, Ga., claimed the lives of 119 persons. These fires had one thing in common. In all three fires, rapid flame spread along the surfaces of interior finish was judged to be a major factor in the spread of fire. Two had burlap wall coverings, and the other an early type of plywood which seriously delaminated. The fire protection authorities investigated several test methods with the objective of providing one that could be used to regulate interior finish materials and minimize repetition of such fires. These tests included: The Forest Products Laboratory Fire Tube Test (now Test Method E 69); Federal Specification SS A118b (acoustical tile/bunsen burner test) (replaced by SS-A-118a-7/63-referencing Test Method E 84); New York City Timber Test and Shavings Test (now obsolete); Crib Test-Specification C 160 – 41 T (now

Test Method E 160); and The Swedish Schlyter Test. ⁽¹⁾¹⁰ All of these were relatively small laboratory tests. Test Method E 84 was developed on the premise that a large test would provide a more realistic and comprehensive test, and it has since been widely adopted for use by the building code authorities to regulate the use of interior finish materials. Subsequently during this same period, two other test methods were developed for use in research and development of new materials, the NBS Radiant Panel (Test Method E 162) and the FPL 8-ft tunnel (Test Method E 286). These test methods have been widely used for research and development purposes.

X4.2 History of Test Method E 84

X4.2.1 The first “tunnel-type” furnace was built at Underwriters Laboratories around 1922 when “fire-proofing” paints and specifically “white wash” were actively promoted. The equipment consisted of a long bench with a noncombustible top. The sample consisted of a wood trough about 16 ft long, 18 in. wide, and 18 in. deep (5.568 m long, 0.522 m wide, and 0.522 m deep), placed upside down on the bench. The inside of the trough was coated with the paint. A known quantity of wood at one end furnished the ignition source.

X4.2.2 In 1927 and 1928, chemically impregnated wood was being developed, and Underwriters Laboratories, Inc.,

¹⁰ The boldface numbers in parentheses refer to the list of references at the end of this test method.

used a tunnel 36 in. wide, 23 ft long, and 13 in. deep (1.044 m wide, 8 m long, and 0.377 m deep) to evaluate its performance. It was during this time that red oak flooring was selected as a control to calibrate the furnace. The sample formed the top of the tunnel. The fuel and draft were also controlled.

X4.2.3 In the early 1940's, a desire to reduce flammability of wood-based products, and the introduction of new building materials and combinations of materials brought about the need to further improve the tunnel. The development of the third tunnel furnace is explained fully in Underwriters Laboratories Bulletin of Research No. 32 (2). Subsequent refinements were incorporated, and the first formal test method was published as Standard U.L. 723 by Underwriters Laboratories in August 1950. Revised editions were published in 1958, 1960, 1971, 1977, and 1979. The National Fire Protection Association adopted the method as NFPA No. 255 in 1955 with revisions in 1958, 1961, 1966, 1970, 1972, and 1979. The test was adopted by the American Society for Testing and Materials as a tentative standard in 1950 and formally adopted in 1961 with revisions made in 1967, 1968, 1970, and from 1975 through 1980.

X4.2.4 The tunnel has been designated the "Steiner Tunnel" by Underwriters Laboratories in honor of Albert J. Steiner (3) who had spent much time developing this and many other fire test methods.

X4.2.5 Since 1950 the flame spread properties of materials, as measured by this method have been reported as ratings, classifications, or indices. The last is considered more indicative of the nature of the results and is the present terminology used in the standard. The original method of determining "flame spread index" was based on either the ratio of the time at which flames traveled the full tunnel length or the partial flame travel distance relative to that of red oak. In 1968, a change was made in the FSI calculation to account for an anomaly between results for flame spread greater than or less than 13½ ft. In 1976, the flame spread index was changed to an area basis (4). Here the total area under the distance-time curve, ignoring any flame-front recession, was compared to a prescribed area typical of red oak flooring. The current calculation method (see Appendix X2) uses a formula that takes the rate of flame travel into account.

X4.2.6 The sensitivity study by Endicott and Bowhay (5) in 1970 has led to a concerted effort by the "ASTM tunnel operators group" to address concerns identified by the report. Since 1975 a series of changes have been specified in the standard. These include defining duration of furnace preheating, the incorporation of a floor thermocouple, as well as more closely specifying details of furnace construction and standardization.

X4.2.7 Particular attention is being paid to the refinement of the apparatus and procedure involved in the measurement of the smoke generated during testing. Round-robin tests that have been conducted to date have indicated large differences in smoke developed values for interlaboratory tests on replicate specimens.

X4.2.8 Some of these revisions include standardization of the smoke-density measuring equipment, its location in the exhaust duct, and its orientation. The measurement of smoke

density is reported in terms of the area under the light absorption time curve related to a similar curve for red oak. Since the quality of vision obscuring particles in the smoke column is not linearly related to light absorption, this procedure has been criticized by some parties. The method does however provide a basis for comparisons.

X4.2.9 In 1970, a revision to the scope was adopted to emphasize that there was no direct relationship between the flame spread index (FSI) and the fuel contributed or smoke density index (SDI). This revision was deemed necessary because some enforcement officials were assigning equal significance to the values.

X4.2.10 Prior to 1978, the report of tests included an evaluation of the fuel contribution as well as the FSI and SDI. However, it is now recognized that the rise in temperature of the thermocouple located near the end of the tunnel, on which it is based, does not provide a valid measure of fuel distribution. Therefore, although the data are recorded during the test, this information is no longer normally reported.

X4.2.11 Appendix X1 adopted in 1968 is intended as a guide for the mounting of specimens. It is not a mandatory part of the method, since the intent of the method is that the specimen be tested as closely as possible to the manner in which it will be applied in general use. In 1978, revisions were made that dealt with the testing of adhesives, the description of a wood substrate for testing coatings, and the definition of the properties of the fiber-cement board used as a standard backing and the metal rods used as supports.

X4.3 Fire Exposure Conditions

X4.3.1 The tunnel test fire exposure is provided by a 4½-ft (1.35-m) long test flame, covering approximately 7 ft² (0.63 m²) of the 36 ft² (3.25 m²) of the exposed specimen surface during the 10-min test period. It releases heat at a rate of approximately 5000 Btu/min (88 kW) and creates gas temperatures near the specimen surface of up to 1600°F (900°C).

X4.3.2 The size and heat release rate of the exposing flame, developed after repeated experiment tests, although not optimum fire conditions, were selected to produce a flame spread over the entire length of the calibration material in about 5½ min (1). It was found that conditions could be changed so that flames would spread faster, but these conditions caused the flame to spread too fast to make the necessary observations of the flame spread, smoke density, and temperature rise of the thermocouple.

X4.4 Furnace Calibration

X4.4.1 Select red oak was chosen as a control material because this term denoted a fairly uniform grade of lumber nationally, whereas many other designations have a purely local significance. It is readily available, usually uniform in thickness and moisture content, and generally gives repetitive results. In recent years, experiments have been run using man-made materials such as particleboard in the hope of further refining the repeatability, however, red oak is still used as a calibrating material.

X4.4.2 The operating conditions of the tunnel are adjusted if necessary to ensure that the flame spreads to the end of the tunnel in 5.5 ± 0.25 min, for a specimen of red oak flooring.

Tests are run with an inorganic fiber-cement board (ACB) specimen to establish the distance of the exposing flame at 4.5 ft. It should be noted that the calibration specifies only the time at which the flame passes over the end of the specimen. The FSI depends on the area under the flame spread versus the time curve. Therefore, the FSI of red oak is no longer exactly 100 as originally specified.

X4.4.3 Recognition of the importance of turbulence, including the role of fire bricks and of window recesses, resulted in a revision in the method in 1976 (see 5.1.3 and 5.1.7.2).

X4.5 Repeatability and Reproducibility

X4.5.1 Four round-robin tests have been conducted: the first in 1958 between Underwriters Laboratories and Southwest Research Institute; the second in 1959 sponsored by the former Acoustic Tile Assn. among four laboratories using four different tiles (6); the third in 1973 on floor coverings by the National Bureau of Standards with eleven cooperating laboratories (7); the fourth in 1978 on loose-fill cellulosic insulation by the Consumer Product Safety Commission with six laboratories (8); others are now in process under the auspices of ASTM Committee E05. A precision and bias statement is being prepared. In the interim, the reader is directed to the round-robin reports if information on precision and bias is needed.

X4.5.2 An ASTM task group of Subcommittee E05.22 composed of tunnel operators is now working on comprehensive design and on operational and procedural revisions to improve uniformity among facilities (9).

X4.6 Advantages and Problems

X4.6.1 Test Method E 84 results have generally showed performance similar to that observed during accidental building fires for some materials and exposure. *It should be emphasized however that it is the intent of this test method to provide only comparative classifications.*

X4.6.1.1 It provides a large flaming fire exposure, with specimen thermal exposure and area coverage sufficient to bring about progressive surface burning and combustible volatile generation characteristic of the materials under evaluation resulting in a moving, wind-aided flame front.

X4.6.1.2 It involves a large specimen, nominally 36 ft² (3.25 m²) of exposed area, allowing for realistic fire involvement of material surfaces and the development of physical and structural failures (collapse, buckling, large ruptures or cracks, etc.) that may influence flammability performance during the test period.

X4.6.1.3 It may be applied to a wide range of materials, including composite constructions of faced or laminated boards, panels, units, or sections in actual field-installed thicknesses.

X4.6.1.4 It may be used to measure the effects of density, thickness, surface contour, surface finish, delamination, strength, and joint design on the surface flammability of the specimen.

X4.6.1.5 It does characterize most high-flame spread materials identified as having been involved in rapidly developing field fires (for example, highly combustible coatings on wood products, certain cellulosic acoustical materials, insulation facings applied with combustible adhesives, etc.), as well as

providing an accurate characterization of the performance of some low flame-spread materials in actual fires (for example, gypsum and mineral products).

X4.6.1.6 Although this is a test to measure “surface burning characteristics,” the visual observation of flame travel is based on maximum flame extension anywhere within the tunnel volume, not necessarily directly on the specimen surface that may not be clearly visible. Surface flammability measurements of building materials do not yield a unique material property. Rather, the measurement is influenced by the method of test to a very considerable degree.

X4.7 Uses and Limitations

X4.7.1 The orientation of the specimen in this method is in a horizontal ceiling position. This orientation places some limitations on the type of material that can be realistically mounted during testing. Prior to 1960, the tunnel was used primarily for the investigation of the surface burning characteristics of homogeneous compositions of ceiling and wall finishes, such as acoustical tiles, wall coverings, coatings, and various types of decorative panel, all being able to support themselves in the ceiling position throughout the test.

X4.7.2 Through adaptation (Appendix X1 on Guide to Mounting Methods added in 1968), the procedure was expanded to include the evaluation of composites and assemblies. The guide contains mounting suggestions for a number of individual categories of product classifications, including: acoustical and similar panel products; composite building units; adhesives, batt- and blanket-insulating materials; fire-retardant and general-purpose coatings; loose-fill thermal insulations; treated and untreated plywoods; lumber and wood composition boards; foamed, molded, reinforced, and laminated plastics; and sheet-type wall coverings.

X4.7.3 The difficulty of defining materials that contribute little or no fuel to a fire has in the past led to the use of Test Method E 84 to provide information about the combustibility of materials. ASTM Committee E5 does not and has not ever recommended that the results of these tests be used alone to describe material combustibility.

X4.7.4 Composite assemblies or panels using metal or mineral facings and combustible interior cores, and which remain essentially impermeable to flame throughout the test period, may not be completely evaluated for surface burning behavior by this method, since the interior cores are not fully challenged.

X4.7.5 Some materials require support to remain in place during the test period, such as loose-fill insulation supported by a metal screen. The supporting screen tends to provide low flame spread indices (FSI) relative to those obtained for materials that are not so supported. Conversely, materials that are supported on rods, such as batt insulation may produce higher FSI if retained on the ceiling rather than allowed to burn on the floor.

X4.7.6 Some materials, such as composites may delaminate during the test. This may cause two possible responses, the material may expose two or more surfaces to the flame increasing the FSI; the material may sag or drop one end into the fire chamber impeding further flame spread.

X4.7.7 Some materials, such as cellular plastics, and thermoplastic and thermosetting materials, may be difficult to evaluate. Thermoplastic and thermosetting materials not mechanically fastened will often fall to the floor of the tunnel and also usually receive relatively low FSI (10). If supported on wire screen, rods or other supports, these materials may be completely engulfed in flame, and a questionable comparison is being made between the surface flame-spread of nominal 1-in. (0.039-mm) thick red oak with the burning rate of these materials. Where the entire specimen is consumed, as compared to the surface burning of red oak, much more oxygen is used and higher smoke developed indexes are usually obtained for these materials.

X4.7.8 The materials described above, that is, those that drip, melt, delaminate, draw away from the fire, or require artificial support present unique problems and require careful interpretation of the test results. Some of these materials that are assigned a low FSI based on this method may exhibit an increasing propensity for generating flame-over conditions during room fire test with increasing area of exposure of the material and increasing intensity of the fire exposure. The result, therefore, may not be indicative of their performance if evaluated under large-scale test procedures. Alternative means of testing may be necessary to fully evaluate some of these materials.

X4.7.9 In order to provide needed technical data, flammability evaluations of cellular plastics for building construction using the Steiner tunnel began with the testing and classification of a flame-retardant formulation of polystyrene foam board in 1960, with subsequent evaluation of polyurethane-

type boards incorporating flame-retardant resin systems (first generation) beginning in 1964, polymerically and chemically modified flame retardant polyurethane type formulations (second generation) in 1965, polyisocyanurate-type foams initiated in 1968 and, most recently, urea-formaldehyde type, cavity-fill foams. Spray-applied and poured-in-place cellular foam systems were first subjected to the test in 1968 and 1972, respectively.

X4.7.10 From 1960 through 1973, in excess of 2000 tunnel tests have been conducted on flame retardant and general-purpose polystyrene, polyurethane, polyisocyanurate and urea-formaldehyde cellular plastics, in board-stock, spray-applied or pour-in-place forms, yielding flame spread values ranging from less than 5 to over 2000. See Ref (11) for full report on one test series.

X4.7.11 The flame spread index of some materials may vary depending upon environmental conditions. The prescribed limits on the temperature and relative humidity for specimen conditioning and tunnel air supply (both $73.4 \pm 5^\circ\text{F}$, $50 \pm 5\%$ relative humidity) were selected to minimize these effects.

X4.8 Correlation with Other Fire Conditions

X4.8.1 Several studies have been made to examine the relationship of the FSI test results on materials with their performance in large scale fire growth experiments and with their performance in other laboratory test methods. Some comparisons with large scale experiments are given in the references. Comparisons have also been made between Test Methods E 84, E 162, E 286, the “2-ft tunnel test,” the “corner test” (12) and other tests.

REFERENCES

- (1) Steiner, A. J., “Burning Characteristics of Building Materials,” *Fire Engineering*, May 2, 1951.
- (2) Underwriters Laboratories, Inc., “Fire Hazard Classification of Building Materials,” *Bulletin of Research*, No. 32, Chicago, IL, September 1947.
- (3) Steiner, A. J., *Building Officials Conference of America Yearbook*, 1949–1950, pp. 115–116.
- (4) Fang, J. B., “Fire Buildup in a Room and the Role of Interior Finish Materials,” *NBS Technical Note 879*, June 1975.
- (5) Endicott, L. E. and Bowhay, R. B., “A Statistical Evaluation of the Fire Hazard Classification Furnace (ASTM E84 – 68),” *ASTM Materials Research and Standards*, May 1970, pp. 19–21, 50–52.
- (6) “Round Robin Tests on Tunnel Type Flame Spread Furnaces” for ASTM Project No. 1–811–2, Final Report, Southwest Research Institute, San Antonio, TX, April 16, 1959.
- (7) Lee, T. G. and Huggett, C., “Interlaboratory Evaluation of the ASTM E84 – 70 Tunnel Test Applied to Floor Coverings,” *Journal of Testing and Evaluation*, Vol 3, No. 1, ASTM, 1975.
- (8) Williamson, R. B. and Baron, F. M., “A Corner Test to Simulate Residential Fires,” *Journal of Fire and Flammability*, Vol 4, April 1973, pp. 99–105.
- (9) Waterman, T. E., “Relation of the Building Occupancy and Design to Use of Combustible Materials on Construction,” IITRI Report, *Society of Plastics Industry, Inc.*, IIT Research Institute, Chicago, IL, October 1968.
- (10) D’Souza, M. V. and McGuire, G. H., “ASTM E84 and the Flammability of Thermosetting Plastics,” *Fire Technology*, Vol 13, No. 2, May 1977, pp. 83–94.
- (11) Underwriters Laboratories, Inc., *Flammability Studies of Cellular Plastics and Other Building Materials Used for Interior Finish*, Subject 723, U.L., Inc., Northbrook, IL, June 13, 1975.
- (12) McGuire, J. H., “The Spread of Fire in Corridors,” *Fire Technology*, Vol 4, No. 2, May 1968, pp. 103–108.

ASTM International takes no position respecting the validity of any patent rights asserted in connection with any item mentioned in this standard. Users of this standard are expressly advised that determination of the validity of any such patent rights, and the risk of infringement of such rights, are entirely their own responsibility.

This standard is subject to revision at any time by the responsible technical committee and must be reviewed every five years and if not revised, either reapproved or withdrawn. Your comments are invited either for revision of this standard or for additional standards and should be addressed to ASTM International Headquarters. Your comments will receive careful consideration at a meeting of the responsible technical committee, which you may attend. If you feel that your comments have not received a fair hearing you should make your views known to the ASTM Committee on Standards, at the address shown below.

This standard is copyrighted by ASTM International, 100 Barr Harbor Drive, PO Box C700, West Conshohocken, PA 19428-2959, United States. Individual reprints (single or multiple copies) of this standard may be obtained by contacting ASTM at the above address or at 610-832-9585 (phone), 610-832-9555 (fax), or service@astm.org (e-mail); or through the ASTM website (www.astm.org).